

Mechanical Dimensions: Inches [mm]

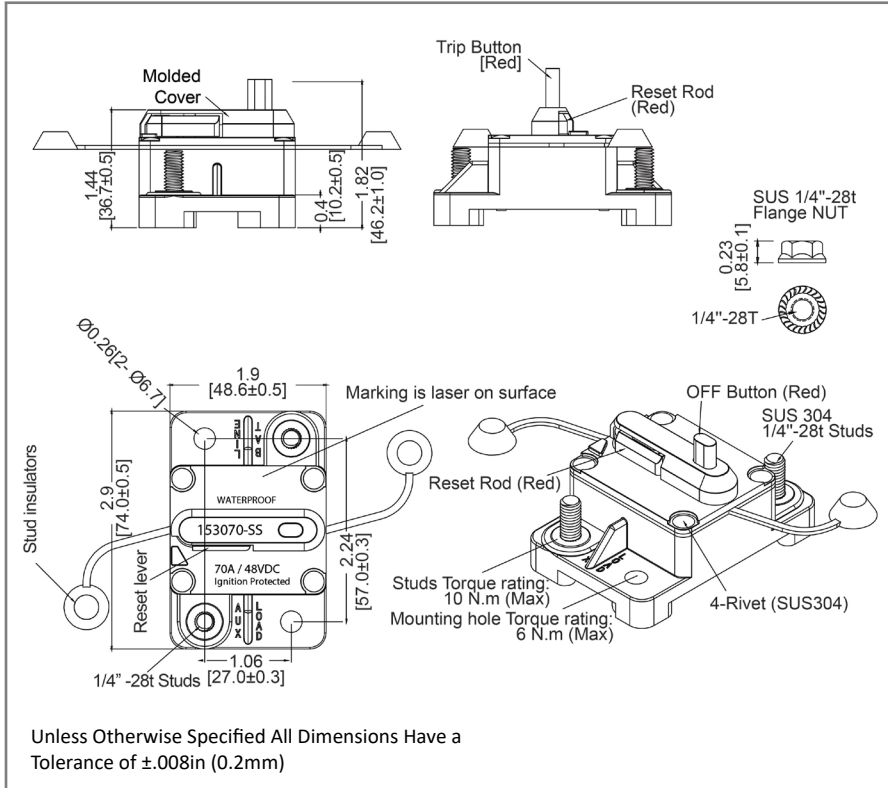

Retail Pack: Inches [mm]

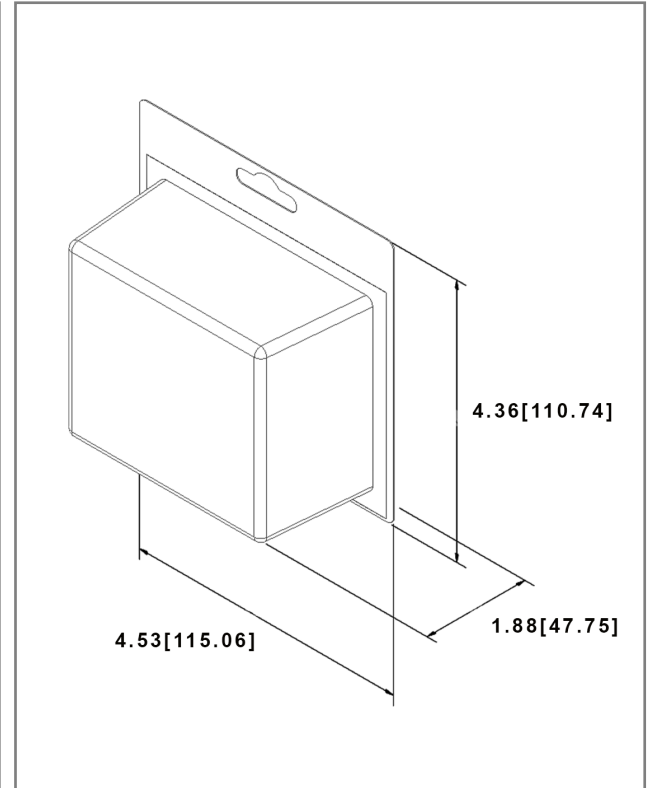

Time vs. Percent of Rated Current

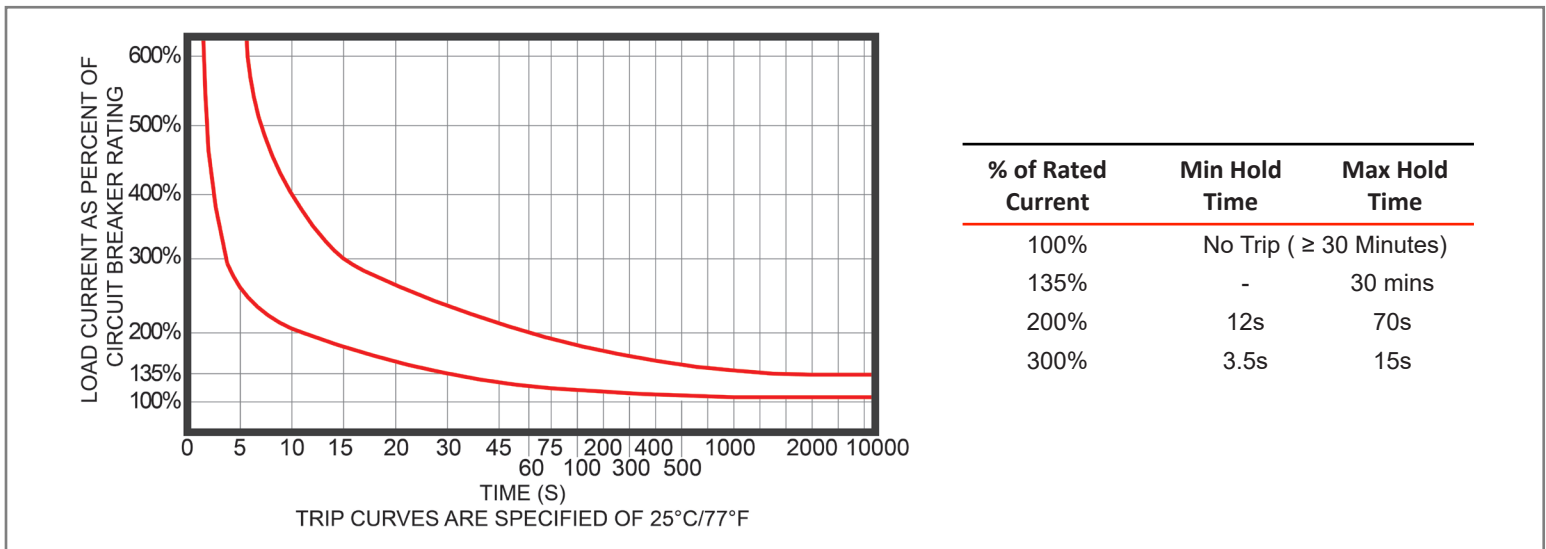

Electrical Specifications

Voltage Rating	48VDC
Reset Type	Type III - Manual Reset
Interrupting Rating	3000A @ 48VDC
Operation Temperature	-40 °F ~ 185 °F -30 °C ~ 80 °C
Testing	SAE J553

Material Specifications

Heavy Duty High Amp - Waterproof Circuit Breaker	
Body Material	Thermoset Plastic (UL94V-0)
Terminals Material	SUS 304
Terminals Configuration	1/4"-28 Stud
Mounting Type	Surface Mount
Ignition Protected	SAE J1171
Ingress Protection	IP67

Part Numbers Information

Amperage	Bulk Part #	Retail Pack # Blister Card	Pack Size
30A	153030-SS	153030-SS-BP	1
40A	153040-SS	153040-SS-BP	1
50A	153050-SS	153050-SS-BP	1
60A	153060-SS	153060-SS-BP	1
70A	153070-SS	153070-SS-BP	1
80A	153080-SS	153080-SS-BP	1
90A	153090-SS	153090-SS-BP	1
100A	153100-SS	153100-SS-BP	1
110A	153110-SS	153110-SS-BP	1
120A	153120-SS	153120-SS-BP	1
130A	153130-SS	153130-SS-BP	1
140A	153140-SS	153140-SS-BP	1
150A	153150-SS	153150-SS-BP	1

Temperature Derating Curve

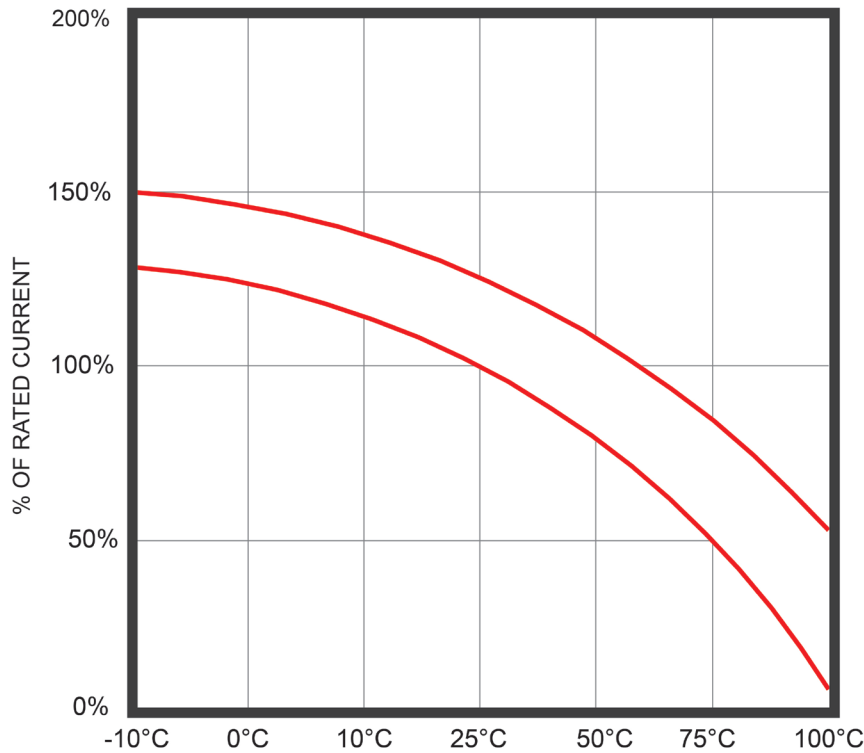

*Graphical data is for reference only. Product should be tested in all applications before use.

Rev	Date of issue	Revision Notes	Designed	Approved
C	01-22-2025	Updated Terminals Material	RC	OF